

Advance ASA-VType/310C

Conveyorised Digital 2-Needle Lockstitch Sewing Machine for Attaching Keder/SEG

Up to
70%
Productivity
Increase

Juki LH-4578C Machine Head

- Digital twin needle lockstitch with automatic thread trimmer, backtack, and footlift.
- Fabric detection sensor to finish seams perfectly every time.
- Automatic stitch length to belt speed synchronisation.



Effective. Versatile. Deskilled.

The ASA-VType/310C digital conveyor is cutting-edge, industry 4.0 ready sewing system and is the flagship model for the next generation of automated conveyorised machines. Engineered for productivity, versatility, and ease of use, it is the ultimate solution for wide-format display graphics production. Trusted across the UK and Ireland, Europe, and the USA, the VType excels in Keder/SEG attaching, with precision trimming for mitred corners (single-needle operation), large area sewing for flags and banners (with a hemming folder), and Velcro attaching (two-needle operation). Contact our team to find out more about how the VType can transform your production process.

ADVANCE ASA-VTYPE/310C SPECIFICATIONS

| | |
|----------------------|---------------------|
| CONVEYOR BELT LENGTH | 3m (can be altered) |
| CONVEYOR BELT WIDTH | 1m (can be altered) |
| MACHINE HEIGHT | 90cm as standard |
| POWER REQUIREMENTS | 240V |
| AIR REQUIREMENTS | 5 bar |



Fully Customisable

These machines are built to order by our team in the UK and can be fully customised to suit your requirements, including alternative machine heads and belts.

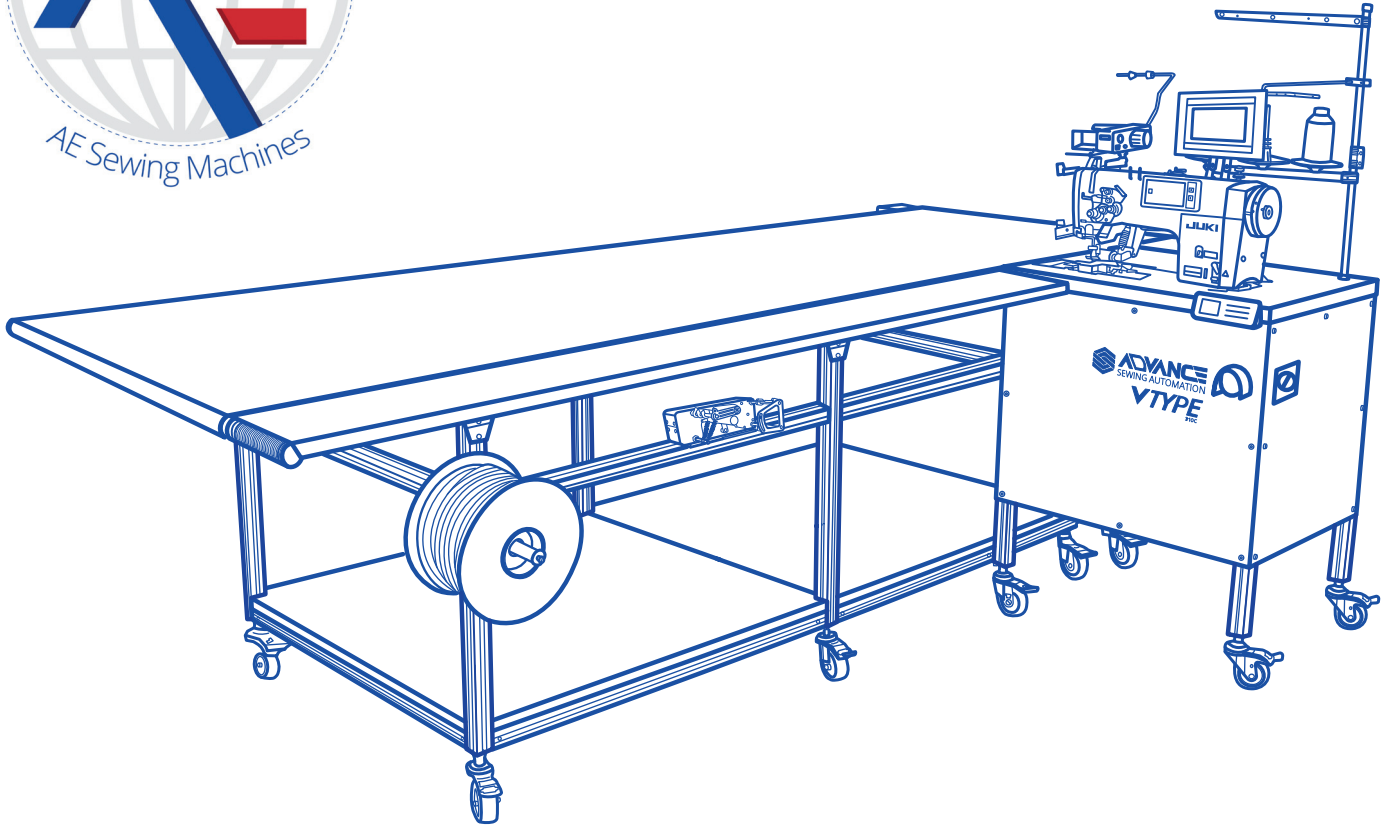

Signs and Graphics

Specialist Industrial Textile Equipment for Sign Makers
Including Automated Sewing Solutions for Attaching
SEG/Keder.



www.ae-sewingmachines.co.uk
info@ae-sewingmachines.co.uk
01978 821 699